



Sentinel Power

User Manual

HW Version: P2

FW Version: 5.7.4

Document revision 4

Revision date: 2010-11-22

Contents.....	2
1 Notice.....	4
1.1 Certification directives	4
1.2 Safety instructions	6
1.2.1 Introduction	6
1.2.2 General rules for all users	6
1.2.3 User guide	7
1.2.4 Differentiation of degrees of risk	7
2 Sentinel Power and Network Description.....	8
2.1 About the Sentinel Power.....	8
2.2 Sentinel Power	9
2.2.1 Detailed Description.....	9
2.2.2 Models Description	10
2.2.3 Main Characteristics.....	12
2.3 Network	13
2.3.1 Network Characteristics.....	13
2.3.2 Introduction	13
3 Hardware Installation and Control.....	14
3.1 Important warning and notices	14
3.2 Before You Start.....	15
3.3 Network deployment recommendations	15
3.3.1 Basic guidelines	15
3.3.2 Sentinel Power location	17
3.4 Sentinel Power Mounting Instructions	18

3.4.1	Wall and panel Mounting.....	18
3.4.2	DIN Rail Mounting.....	18
3.4.3	Current sensors mounting	19
3.4.4	Voltage Input connection.....	21
3.4.5	LED indicator description	23
3.4.6	Network commissioning	24
3.4.7	Software.....	25
3.4.8	Sentinel Power Specific data.....	25
4	Glossary.....	28
4.1	Glossary and Symbols	28

1.1 Certification directives

The present product is designed to fully agree with the following directives: CE, FCC

- Federal Communication Commission Interference Statement

This equipment has been tested and found to comply with the limits for a Class B digital device, pursuant to Part 15 of the FCC Rules. These limits are designed to provide reasonable protection against harmful interference in a residential installation. This equipment generates, uses and can radiate radio frequency energy and, if not installed and used in accordance with the instructions, may cause harmful interference to radio communications. However, there is no guarantee that interference will not occur in a particular installation. If this equipment does cause harmful interference to radio or television reception, which can be determined by turning the equipment off and on, the user is encouraged to try to correct the interference by one of the following measures:

- Reorient or relocate the receiving antenna.
- Increase the separation between the equipment and receiver.
- Connect the equipment into an outlet on a circuit different from that to which the receiver is connected.
- Consult the dealer or an experienced radio/TV technician for help.

FCC Caution: Any changes or modifications not expressly approved by the party responsible for compliance could void the user's authority to operate this equipment. (15.21)

This device complies with Part 15 of the FCC Rules. Operation is subject to the following two conditions:

(1) This device may not cause harmful interference, and (2) this device must accept any interference received, including interference that may cause undesired operation. (15.19)

IMPORTANT NOTE:

FCC Radiation Exposure Statement:

This equipment complies with FCC radiation exposure limits set forth for an uncontrolled environment. This equipment should be installed and operated with minimum distance 20cm between the radiator & your body.

This transmitter must not be co-located or operating in conjunction with any other antenna or transmitter.

- Industry Canada statement:

This device complies with RSS-210 of the Industry Canada Rules. Operation is subject to the following two conditions:

(1) This device may not cause harmful interference, and (2) this device must accept any interference received, including interference that may cause undesired operation.

IMPORTANT NOTE:

Radiation Exposure Statement:

This equipment complies with IC radiation exposure limits set forth for an uncontrolled environment. This equipment should be installed and operated with minimum distance 20cm between the radiator & your body.

For more information, contact Aginova's customer service.

1.2 Safety instructions

1.2.1 Introduction

1.2.1.1 Principle

The user must have read and understood this chapter before undertaking any action with / in the system. For all information considered inadequate, please contact the manufacturer or your local representative.



FAILURE TO FOLLOW THESE INSTRUCTIONS MAY CAUSE SERIOUS ACCIDENTS!

All device users, such as:

- owners;
- installers, maintenance and service personnel, or any other person in related job functions;
- managers, operators, setters, programmers, foremen, mechanics;

must read and strictly follow the safety instructions in this document.

These regulations also pertain to options, components, installations, devices and systems related to the machine.

1.2.1.2 Importance of safety indications

All the safety and protection instructions given in this manual must be respected to prevent reversible or irreversible bodily injuries, material damages or environmental pollution. Similarly, legal regulations, accident prevention and environment protection measures, as well as recognized technical regulations, aimed at appropriate risk-free work methods in force in the country and in the machine workspace must be respected.

1.2.1.3 Failure to respect safety regulations

Any non-respect of the safety and protection rules, as well as existing legal and technical regulations, could cause reversible or irreversible bodily injuries, material damages or environmental pollution.

1.2.2 General rules for all users



READ AND FOLLOW THE USER INSTRUCTIONS AND MANUALS DELIVERED WITH THIS SYSTEM. ONLY PEOPLE TRAINED FOR MANIPULATIONS AND ACQUAINTED WITH THESE INSTRUCTIONS CAN WORK ON THE DEVICE.

1.2.3 User guide

- User instructions and user guide delivered by the manufacturer with the system or at a later date must be brought to the attention of all people operating on the device or responsible for it in any way;
- These people must read and strictly follow the user instructions and manuals;
- After the reception of updates, if any, the user will update the documentation.
- Anyone likely to work on the device must have access to the user instructions and manuals.



DOCUMENT TO BE KEPT TO REFER TO IT LATER ON !

1.2.4 Differentiation of degrees of risk

1.2.4.1 General risks



WARNS AGAINST A DIRECT DANGER OF DEATH OR SERIOUS INJURY



INDICATES INCORRECT ACTIONS WHICH MAY CAUSE MINOR HUMAN INJURY OR MAJOR MATERIAL DAMAGE TO THE SYSTEM AND ENVIRONMENT.



FOR INFORMATION, INDICATES HANDLING ERRORS OR NEGLIGENCE WHICH MAY CAUSE MATERIAL DAMAGE ON THE DEVICE

1.2.4.2 Electric cabinet or live components



ONLY A QUALIFIED PERSON IS AUTHORIZED TO INTERVENE INSIDE THE ELECTRIC CABINETS OR ON A LIVE COMPONENT.

2 Sentinel Power and Network Description

2.1 About the Sentinel Power

The Sentinel Power is a complete data acquisition platform to measure and transmit electrical parameters used for Energy Management application. As it is an open architecture, this platform can be easily interfaced with existing data logger and energy monitoring software.

The Sentinel Power is a sub-meter which calculates several electrical parameters with pre-wired split core current transformers or Rogowski coils and embedded wireless data transmission (for more information, see next page).

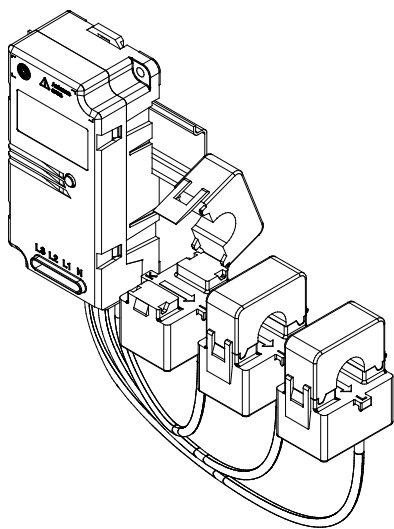

Figure 1 - Sentinel Power with Current Transformer (CT)

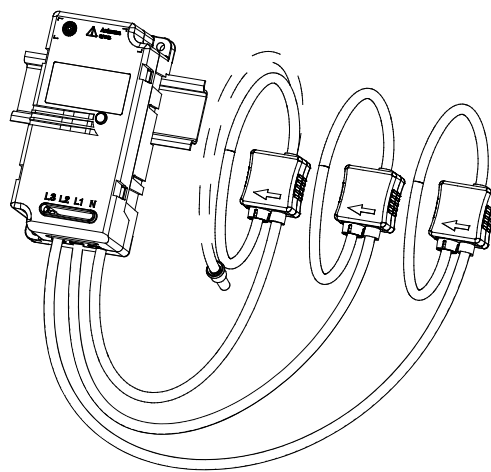

Figure 2 - Sentinel Power with Rogowski coil (RT)

2.2 Sentinel Power

The Sentinel Power is a 3-phase electric meter with a wireless (radio) communication.

1. Led indicator

For more information about the LED indicator, see chapter 3.4.5.

2. Antenna

3. Clipping fixture for DIN Rail

4. Identification label (ID)

5. Current Transformer (CT) or Rogowski coil (RT)

6. Voltage input

2.2.1 Detailed Description

Data from the meter is periodically sent to the WiBox gateway for user access.

The meter data is split into three sections:

- Energy Meter: Active, reactive and apparent energy per phase and sum with a time-stamp.
- Recording Interval Meter: Active, reactive and apparent energy per phase and sum with a time-stamp of the end of the recording interval;
- minimum voltage per phase and maximum current per phase during recording interval; frequency
- Meter Identification and Configuration:
Meter configuration and version;
recording interval time setup, command and status word.

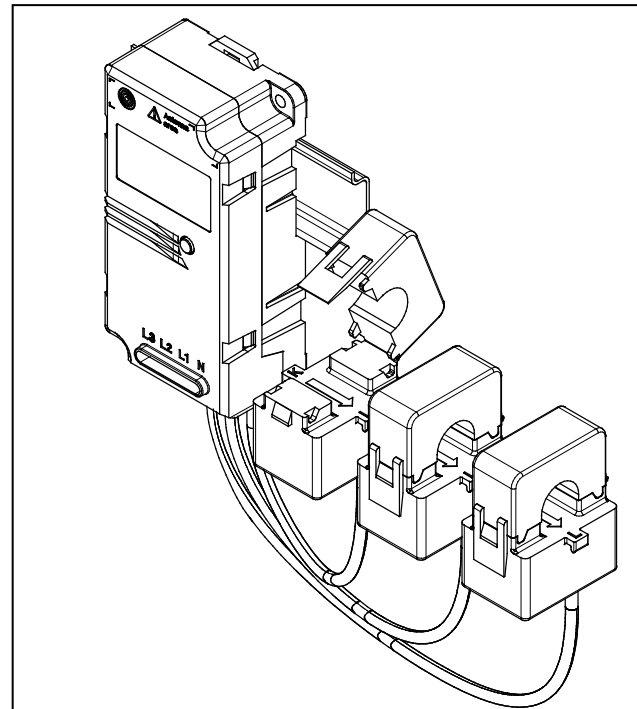

Figure 3 - Sentinel Power with CT

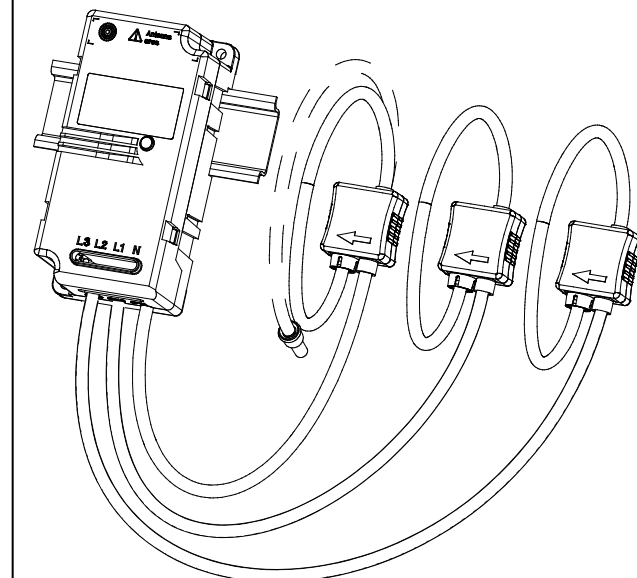
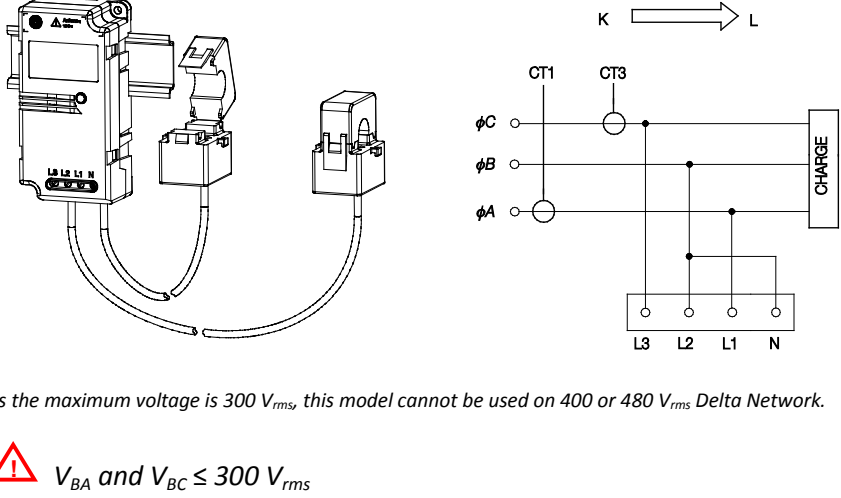

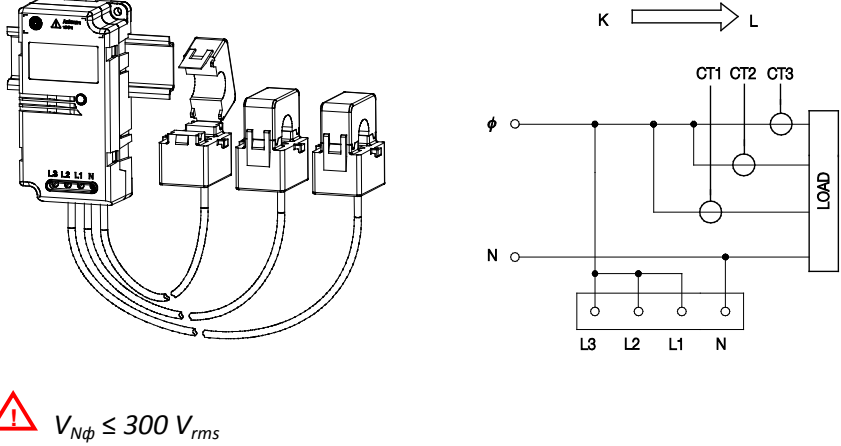

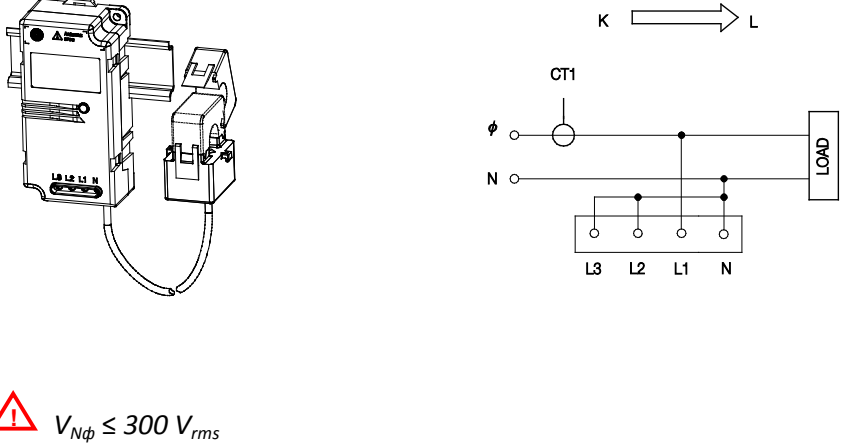



Figure 4 - Sentinel Power with RT

2.2.2 Models Description

The following table lists the different models of Sentinel Power Sensors available.

Model*	Wiring Diagram (CT and RT)
EMNxxxD3 (Delta - 3 wires) Code: 111	 <p>As the maximum voltage is $300 V_{rms}$, this model cannot be used on 400 or 480 V_{rms} Delta Network.</p> <p> V_{BA} and $V_{BC} \leq 300 V_{rms}$</p>
EMNxxxW0 (3 single phases on same voltage) Code: 101	 <p> $V_{N\phi} \leq 300 V_{rms}$</p>
EMNxxxW2 (Single phase - 2 wires) Code: 010	 <p> $V_{N\phi} \leq 300 V_{rms}$</p>

EMNxxxW3
(Wye - 3 wires)
Code: 011

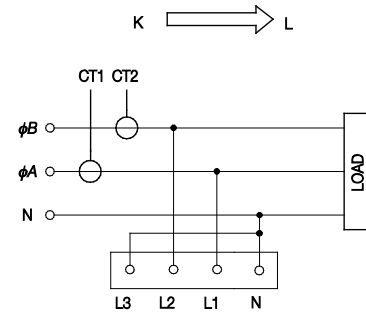
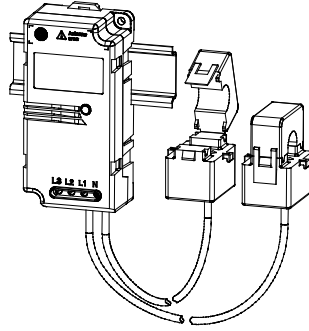

$V_{NA} \text{ and } V_{NB} \leq 300 V_{rms}$

EMNxxxW4
(Wye - 4 wires)
Code: 000

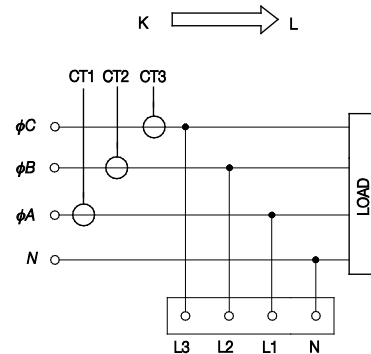
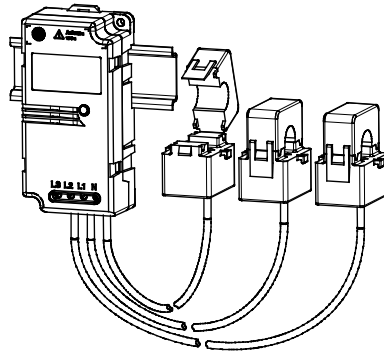

$V_{NA}, V_{NB} \text{ and } V_{NC} \leq 300 V_{rms}$

EMNxxx-D3/SP2
(Delta - 3 wires)
Code: 111

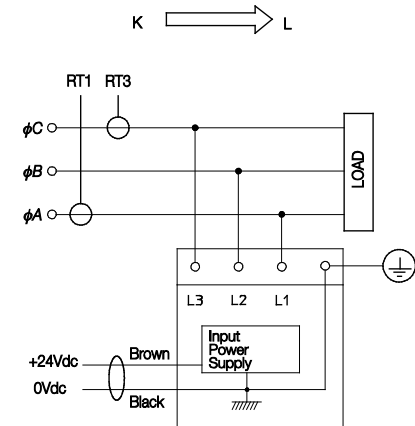
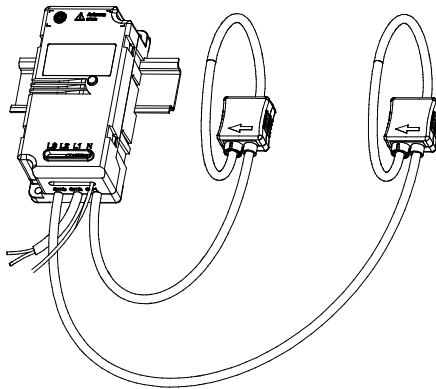

This specific model has been developed for up to 520 V_{rms} Delta Network

$V_{BA} \text{ and } V_{BC} \leq 520 V_{rms}$ $V_{A,B,C} - \text{earth} \leq 300 V_{rms}$

This device being Isolation Class 1, it must be connected to Earth/Ground (use Green/Yellow wire)

* for more information about model names, see chapter XXX "Model configuration"

2.2.3 Main Characteristics

2.2.3.1 Sentinel Power Line powered up to 300V_{rms} ⁽¹⁾

• Primary Nominal Current:	20A ... 2000A (according to the model)
• Primary Voltage, Measuring Range (neutral/phase) (V _{PN}) ¹⁾ :	90 to 300 V _{rms}
• Primary Voltage , Nominal Range (N/L) (V _{PN}):	100 to 272 V _{rms}
• Absolute Min/Max input voltage (N/L):	90 to 300 V _{rms}
• Frequency (f):	50 / 60 Hz
• Maximum power consumption.....	2 W
• Maximum supply current (N-L1)	0.2 A _{rms}
• Ambient operating temperature (90% rH) (T _A)	-10 .. + 55°C
• For indoor use only	
• Altitude.....	Up to 2000m
• Protection degree	IP2X
• Pollution degree.....	PD2
• Isolation.....	 Isolation class II IEC 61010-1 CAT III 300 V _{rms}

2.2.3.2 Sentinel Power External power (SP2 model and other)

• Primary Nominal Current (I _{PN}):	100A ... 2000A (according to the model)
• Primary Voltage, Measuring Range (V _{PN}):	180 to 520 V _{rms}
• Frequency (f):.....	50 / 60 Hz
• External power supply (+/- 10%) ²⁾	24 VDC
• Maximum supply current	50 mA DC
• Ambient operating temperature (90% rH) (T _A)	-10 .. + 55°C
• For indoor use only	
• Altitude.....	up to 2000m
• Protection degree	IP2X
• Pollution degree	PD2
• Isolation	Isolation class II IEC 61010-1 CAT III 300 V _{rms}

 Product must be connected to earth (ground)

For more details about technical characteristics, refer to the datasheets about the Sentinel Power series.

1) Maximum voltage limited to 265V_{RMS} for EMN built with firmware V1.xx

2) Must comply with limited-energy circuit criteria and SELV conditions.

2.3 Network

2.3.1 Network Characteristics

- Radio standard: IEEE 802.11b
- RF Band: 2.4 GHz
- Typical Power Emission : 33mW
- Operating range (line of sight) : 100m



DISTANCE MAY CHANGE WITH REGARDS TO BUILDING CONFIGURATION AND NETWORK LAYOUT.

2.3.2 Introduction

The Sentinel Power Sensors operate on standard IEEE 802.11 “WiFi” networks. A typical installation is illustrated on Figure 5. Sentinel Power units are deployed in multiple locations, inside electrical cabinets.

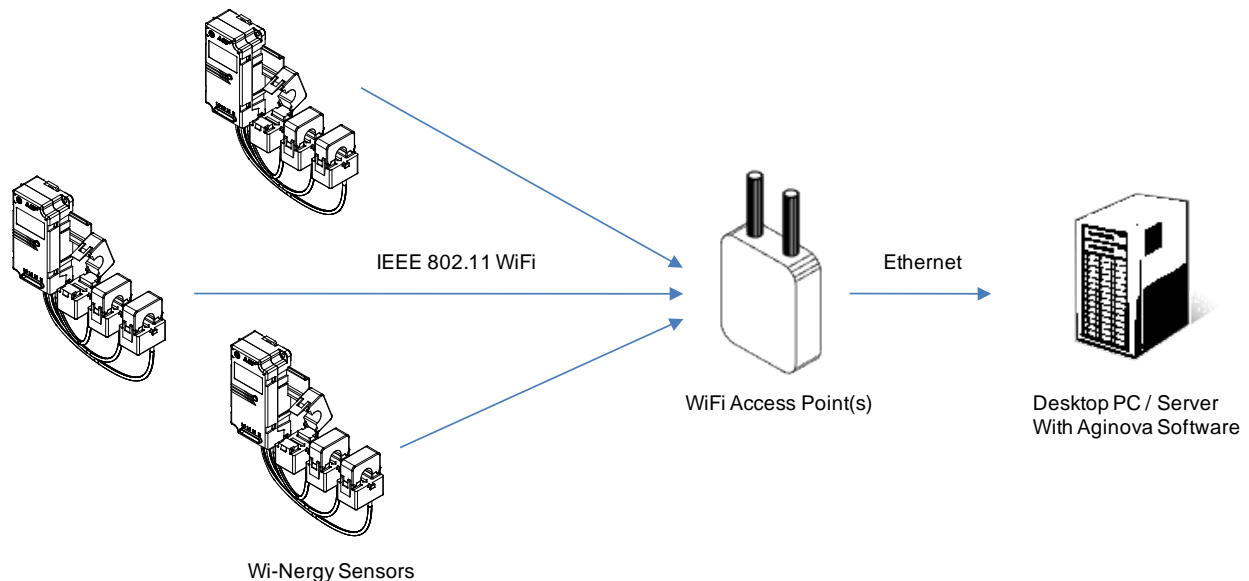

Figure 5 - Typical network topology

The sensors will connect to the nearest WiFi Access Point with strong signal strength and transmit energy measurements wirelessly. The data is then routed by the Access Point to the defined server holding the Aginova Software.

3 Hardware Installation and Control

This chapter describes how to install the hardware to set up the Sentinel Power.

3.1 Important warning and notices



RISK OF ELECTRICAL SHOCK: THIS EQUIPMENT CONTAINS HAZARDOUS VOLTAGE THAT MAY CAUSE SERIOUS INJURY OR DEATH TO PERSONS IF PRECAUTIONS WITHIN THIS GUIDE ARE NOT FOLLOWED. DO NOT REMOVE ANY PART OR CUT SENSOR CABLE OF THE Sentinel Power.



THIS ELECTRIC EQUIPMENT MUST BE USED IN ELECTRIC / ELECTRONIC EQUIPMENT WITH RESPECT TO APPLICABLE STANDARDS AND SAFETY REQUIREMENTS IN ACCORDANCE TO THE MANUFACTURER'S OPERATING INSTRUCTIONS.



INSTALLATION AND SERVICE MUST BE DONE BY QUALIFIED PERSONNEL ONLY ON POWER LOCKED CABINET.



IN CASE THIS EQUIPMENT WOULD BE USED IN A DIFFERENT MANNER AS SPECIFIED WITHIN THIS GUIDE, THE PROTECTION PROVIDED BY THE EQUIPMENT MAY BE IMPAIRED.



EMN AND ITS PREWIRED CURRENT TRANSFORMER ARE DESIGNED FOR USE IN RESTRICTED ACCESS CABINET.

- Do not install the equipment in cabinet which does not provide a sufficient protection level according to the datasheet
- Do not remove or change any part of the product, it may damage it or other equipment or cause serious injury or death.
- In case of accidental degradation of enclosure or other part, do not install the equipment or remove it from installation and carry out its replacement.
- Do not degrade or cut any part of the enclosure and cables.

3.2 Before You Start

- Check carefully that the EMN Model received is appropriate for the system to be monitored. Otherwise, wrong or incomplete data may be sent to the Mesh Gate (MG).
- Read carefully this manual and take care of the warning notes.

3.3 Network deployment recommendations

Prior to define your network and the elements location, read the following information.



WARNING

ALL DEVICES ARE DESIGNED FOR INDOOR USE ONLY.

3.3.1 Basic guidelines

3.3.1.1 Building audit

Our devices all communicate via wireless radio frequencies and are influenced by several factors (electrical wires, metal objects, heavy concrete walls, direction of installed devices, etc.).

Consider the following items in network configuration:

- Number of floors, layout;
- Type of building material;
- Any known obstacles or RF interferences (Heating pipes, electrical room, etc.);
- Detect other 2.4 GHz interference.

3.3.1.2 Walls and floors

Inside a building, radio waves deflections on walls and other objects create interferences.

In case of wall mounting or crossing, take care about both sides of the construction. Depending on materials and wall or floor thickness, radio signal strength will get reduced and distance between devices will be affected.

Usually, floors are hardest to penetrate due to materials used (concrete, cement, tiles, etc.). So, always consider placing routers in stairways and other open spaces available between the floors.

3.3.1.3 Different materials

Glass, sheet rock and wood have least impact to the radio signal.

Concrete and brick walls are much harder to penetrate (maximum distance is half), but anyway distance between two devices will depend on how thick and how many obstacles there are in a way.

Metal is virtually impossible to penetrate and radio communication through such material is only possible thanks to actual open spaces (slits, holes and cracks in the metal.)

3.3.2 Sentinel Power location

3.3.2.1 Basic guidelines

To obtain the best effectiveness of the network, apply the following recommendations.

- Do not install Sentinel Power in front of or close to metallic parts. That may reduce the efficiency of the embedded antenna.
- Avoid proximity of Electromagnetic Induction.
- Respect the illustrated layout to insure an optimized orientation of the antenna.

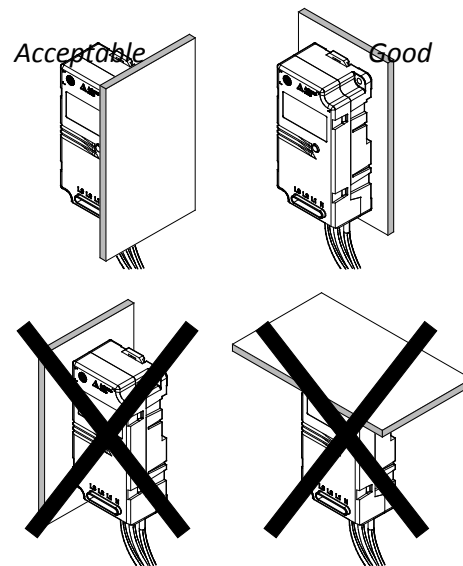

Figure 6 - Avoid the proximity of the antenna with metal parts

3.3.2.2 Inside a metallic cabinet

When Sentinel Power has to be placed inside a metallic cabinet, its location is much more important.

The cabinets are never completely sealed thanks to small open spaces and allow certain radio communication, but significantly reduce signal strength. To get the best effectiveness, apply the following recommendations:

- Do not install Sentinel Power in the centre of the cabinet where all electrical cables are.
- Put Sentinel Power on one side, in front of any door slit or any window (if existing).
- If there is some hole on bottom or top of the cabinet for cables pathways, put Sentinel Power in front of it.
- Add a WiFi Access Point near the vicinity of the cabinet to ensure robust communications.

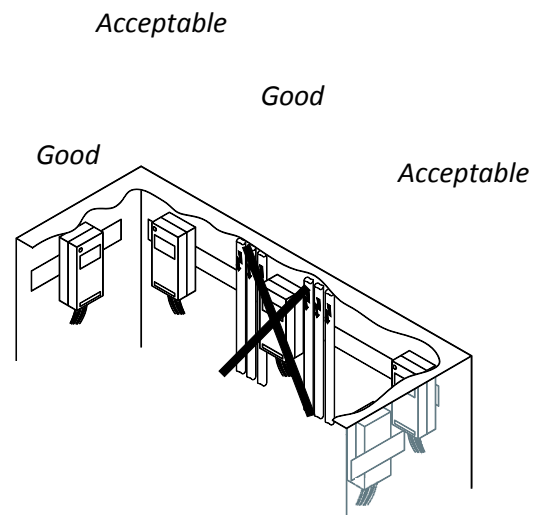

Figure 7 - Location inside a metallic cabinet

3.4 Sentinel Power Mounting Instructions



MAKE SURE THAT THE LOCATION WHERE THE SENTINEL POWER UNIT HAS TO BE FIXED IS POWERED OFF.



SENTINEL POWER MODULE MUST BE INSTALLED VERTICALLY AS SHOWN ON THE FIGURE BELOW.

3.4.1 Wall and panel Mounting

- A. Prepare the mounting holes.
- B. Fix the Sentinel Power to the wall or the panel with the screws (1).

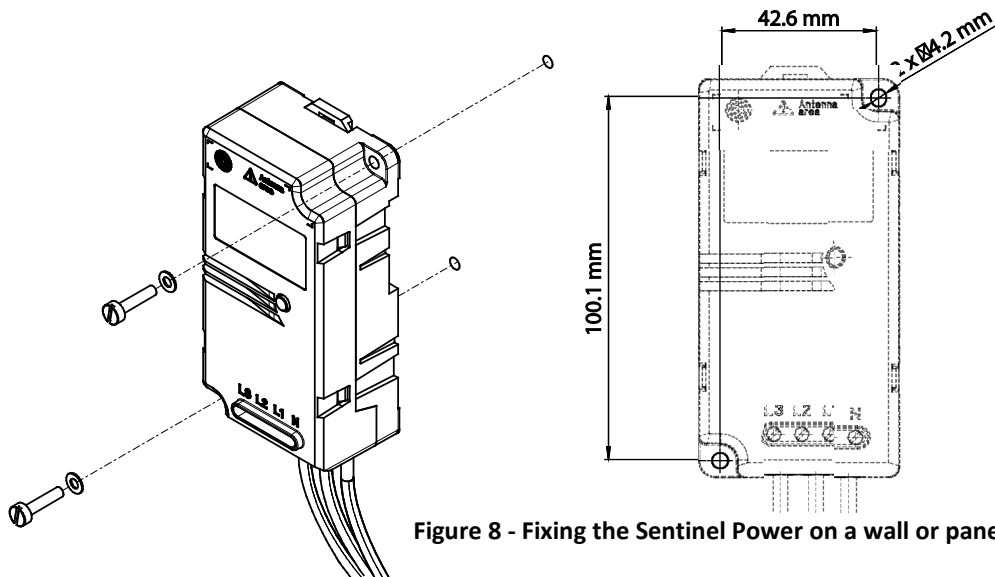

Figure 8 - Fixing the Sentinel Power on a wall or panel

Note: Use max fastening torque 2.8 Nm (2 Lb.-Ft)

3.4.2 DIN Rail Mounting

- A. Clip the EMN on the DIN Rail (3).
- B. Pull up the clipping fixture (2) to remove the EMN from the DIN Rail.

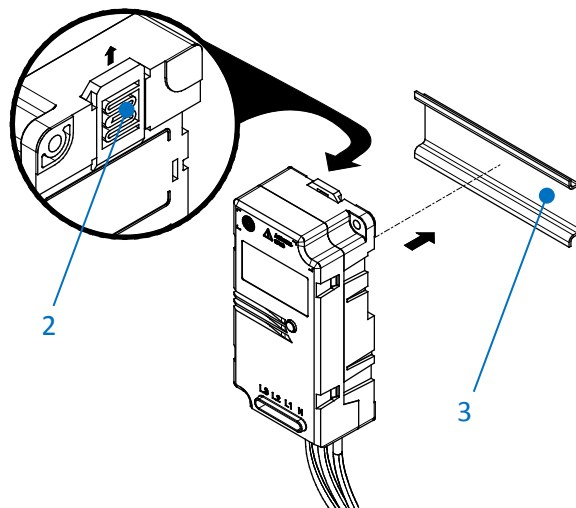

Figure 9 - Fixing the Sentinel Power on a DIN Rail

3.4.3 Current sensors mounting



DANGER

MAKE SURE THAT THE LOCATION WHERE THE SENTINEL POWER UNIT HAS TO BE FIXED IS POWERED OFF.



CAUTION

THESE CURRENT SENSOR ARE DESIGNED FOR LESS THAN 50 OPEN/CLOSE CYCLES, DO NOT USE AS A CLAMP ON METER.



CAUTION

THESE CURRENT SENSORS HAVE BEEN DESIGNED FOR ISOLATED CABLE USE ONLY.

3.4.3.1 Current Transformer



WARNING

KEEP THE MATING SURFACES (2) PARTICLE FREE OTHERWISE ACCURACY MAY BE DEGRADED.

- A. Respect the Current Transformer phase allocation according to Voltage phase allocation.

If the phase allocation is wrong, the EMN will send incorrect energy data.

Refer to chapter 2.2.2 for more details about the phase allocation.

- B. Make sure that the arrow (3) shows the way of the positive current flow from the generator to the load. In this case, the label (6) is facing the load.

This allows the EMN to calculate Active Energy with the right sign.

- C. Close the Current Transformer around the cable (1).
- D. Use the mounting clip (5) to attach the Current Transformer on the cable (4).

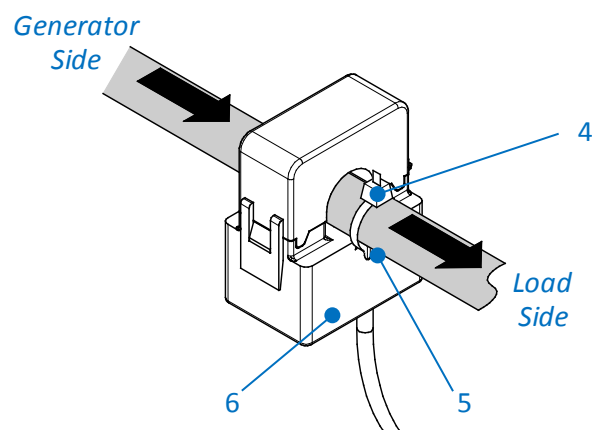
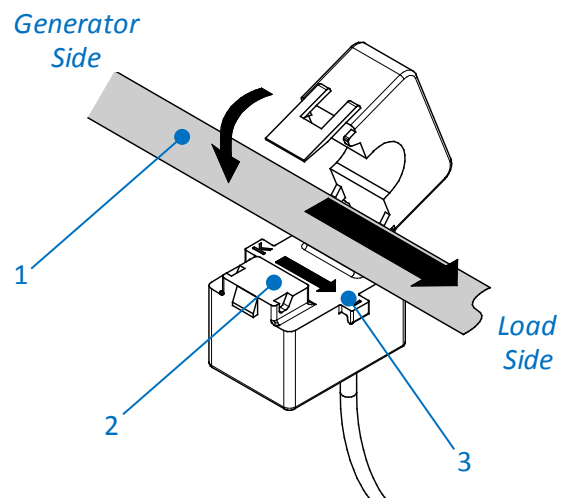

3.4.3.2 Rogowski coil



IN ORDER NOT TO DRAMATICALLY DEGRADE THE ACCURACY , DO NOT STRESS THE COIL APPLYING ANY KIND OF MECHANICAL CONSTRAINT (TWISTING, PRESSING, PUNCHING, STRONG BENDING, ...)

- A. Respect the Rogowski coil phase allocation according to Voltage phase allocation.

If the phase allocation is wrong, the EMN will send incorrect energy data.

Refer to chapter 2.2.2 for more details about the phase allocation.

- B. Make sure that the arrow (3) shows the way of the positive current flow from the generator to the load.

This allows the EMN to calculate Active Energy with the right sign.

- C. Close the Rogowski (2) coil around the cable (1)



ARROW INDICATING THE CURRENT DIRECTION MUST BE INSIDE THE LOOP (3) WHEN CLOSED AS SHOWN ON FIGURE 10

Be sure that the coil is well locked (fully inserted until the click is heard (4)) otherwise accuracy may be degraded.

- D. The Rogowski coil can be let free around the cable / conductor and doesn't need to be attached.

The accuracy won't be affected more than 0.5%, as described within the datasheet, whatever the position of the coil around the conductor.

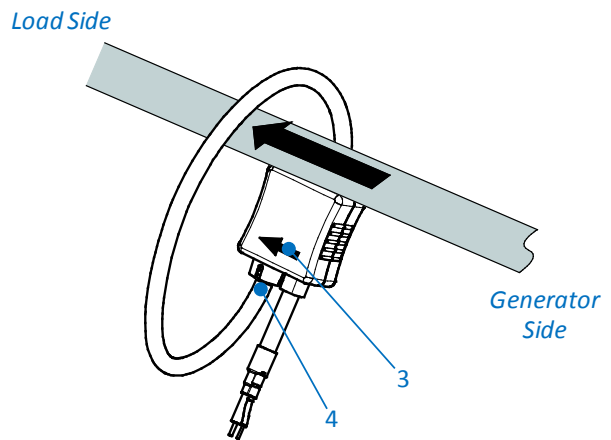
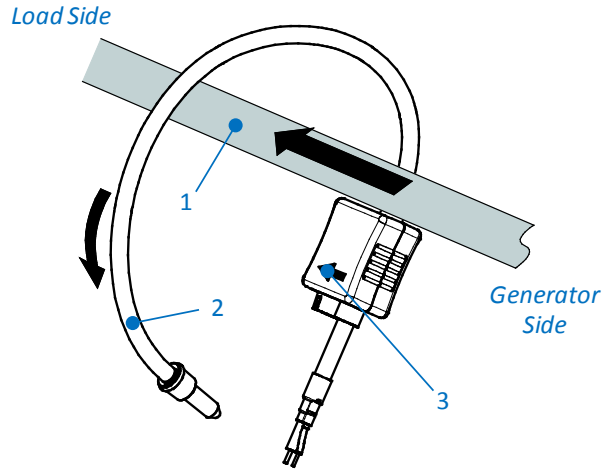

Figure 10 - Rogowski coil mounting

3.4.4 Voltage Input connection



FUSE OR CIRCUIT BREAKER MUST BE INSTALLED BETWEEN THE MAIN SUPPLY AND THE SENTINEL POWER FOR LINE PROTECTION. THE PROTECTION DEVICE MUST BE INSTALLED NEAR THE SENTINEL POWER, MUST BE EASILY ACCESSIBLE AND MUST BE IDENTIFIED AS PROTECTION UNIT OF THE SENTINEL POWER UNIT.

Use a protection with the following characteristics:

Protection range [A]	Wiring [mm ²]	Single fault condition Max trip time [ms]
6.3	1	30
10	1.5	30
16	2.5	30



MAKE SURE THAT THE WIRES YOU CONNECT TO THE VOLTAGE INPUT ARE POWERED OFF.

Refer to «Model Description» on Chapter 2 for more details about the Wiring Diagram of the Sentinel Power.

3.4.4.1 Line powered EMN

- A. Connect the wires from the line to the right Input Voltage connecting points (1).

☞ Use 2.5 mm² wire for single wire and 1 mm² wire for 2 wires.

☞ Use wire > 65°C temperature grade.

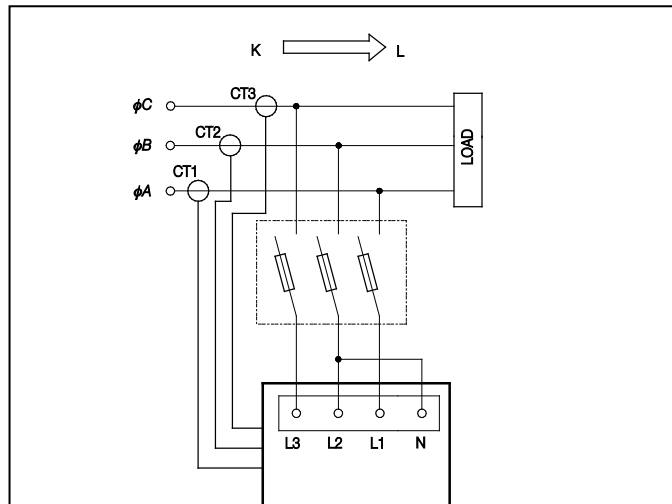

Figure 11 - Example of Fuse holder connection

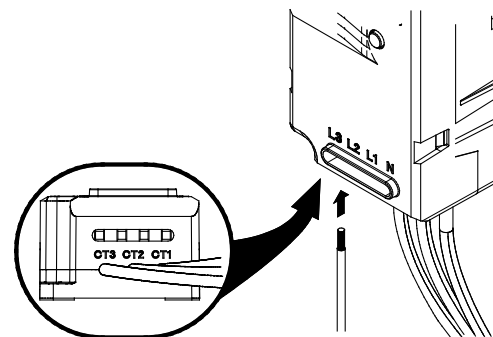

Figure 12 - Connecting the wires to the Input Voltage

24VDC powered Sentinel Power (SP2 models)



SENTINEL POWER MAY PRESENT DYSFUNCTIONS IF THE +/- 10% TOLERANCE AROUND 24 VDC IS NOT RESPECTED.



IT IS NOT RECOMMENDED TO USE THE SAME 24 VDC POWER SUPPLY UNIT FROM OTHER DEVICES EXCEPTION OF OTHER SENTINEL POWER MODULES.

- A. Connect the 2 wires (1) to a 24VDC power supply:
 - Brown: +24VDC
 - Black: 0 VDC
- B. Connect the wire (2) to the earth/ground \oplus

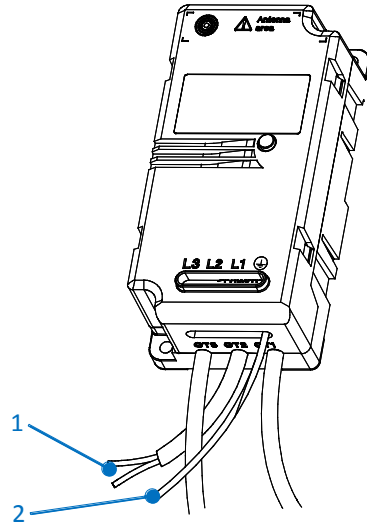

Figure 13 - Connecting the wires to the Input Voltage

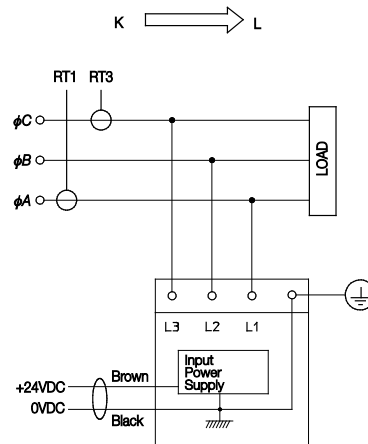

Figure 14 - Example of 24VDC connection

3.4.5 LED indicator description

The LED Indicator (3) has the following status on both models:

1 blink, wait 2 seconds:

Normal operation.

2 blinks, wait 1 second:

Radio module communication error: Sentinel Power is unable to send data.

3 blinks, wait 1 second:

Meter not synchronized to 50/60Hz: Frequency out of range of 50Hz - 10% to 60Hz + 10%.

4 blinks, wait 1 second:

Comm- & Synch error together.

5 blinks, wait 1 second:

Checksum Error: If a reset-meter command followed by an OFF/ON sequence does not reset this error, the calibration memory is corrupted and the device needs to be sent back to Aginova.

6 blinks, wait 1 second:

Direct serial communication mode (factory use only).

7 blinks, wait 1 second:

Internal hardware failure.

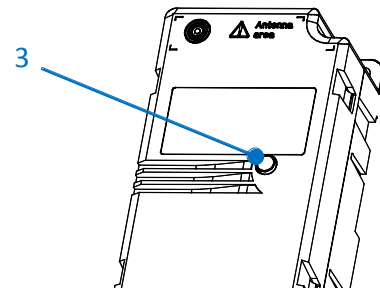

Figure 15 - LED Indicator

3.4.6 Network commissioning

3.4.6.1 Sensor Identification

Each module has two identification numbers: Sensor ID and MAC Address.

The Sensor ID and MAC Address are printed on labels on:

- Sentinel Power front cover

The Sensor ID and MAC address are both unique and any of the two identify a single device. The Sensor ID is mostly used as a human identifier. The MAC Address is the IEEE 802.11 WiFi network MAC address.

3.4.6.2 Default Configuration

All the Sentinel Power sensors are pre-configured with the following settings:

Field	Factory value
SSID	aginova
Channels	1, 6, 11
PSK	aginova1234
WiBox IP Address	192.168.0.10
DHCP	Enabled

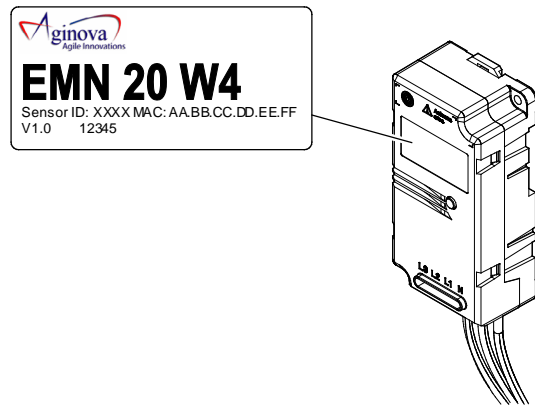

Figure 16 - ID Labels

3.4.7 Software

The Sentinel Power is compatible with the following Software from Aginova:

- Aginova Desktop Software Silver & Gold
- Aginova WiBox Server & API
- Aginova Web Portal

Please refer to the respective user manuals for Software installation & configuration. The following chapters will guide you through Sentinel Power specific parameters.

3.4.8 Sentinel Power Specific data

The following data packets are sent from the Sentinel Power. Each register is 16-bit MSB.

Stored on the sensor:

Register N°	Description	Unit
0	Active Energy Consumption, Phase 1 MSW	kWh
1	Active Energy Consumption, Phase 1 LSW	kWh
2	Active Energy Consumption, Phase 2 MSW	kWh
3	Active Energy Consumption, Phase 2 LSW	kWh
4	Active Energy Consumption, Phase 3 MSW	kWh
5	Active Energy Consumption, Phase 3 LSW	kWh
6	Active Energy Consumption, Phase Sum MSW	kWh
7	Active Energy Consumption, Phase Sum LSW	kWh







Transmitted in “best effort” mode:

Register N°	Description	Unit
8	Reactive Energy Consumption, Phase 1 MSW	kVARh
9	Reactive Energy Consumption, Phase 1 LSW	kVARh
10	Reactive Energy Consumption, Phase 2 MSW	kVARh
11	Reactive Energy Consumption, Phase 2 LSW	kVARh

Register N°	Description	Unit
12	Reactive Energy Consumption, Phase 3 MSW	kVARh
13	Reactive Energy Consumption, Phase 3 LSW	kVARh
14	Reactive Energy Consumption, Phase Sum MSW	kVARh
15	Reactive Energy Consumption, Phase Sum LSW	kVARh
16	Apparent Energy Consumption, Phase 1 MSW	kVAh
17	Apparent Energy Consumption, Phase 1 LSW	kVAh
18	Apparent Energy Consumption, Phase 2 MSW	kVAh
19	Apparent Energy Consumption, Phase 2 LSW	kVAh
20	Apparent Energy Consumption, Phase 3 MSW	kVAh
21	Apparent Energy Consumption, Phase 3 LSW	kVAh
22	Apparent Energy Consumption, Phase Sum MSW	kVAh
23	Apparent Energy Consumption, Phase Sum LSW	kVAh
24	Energy Counter Timestamp, Minutes / Seconds	
25	Energy Counter Timestamp, Day / Hour	
26	Energy Counter Timestamp, Year / Month	
27	Line Frequency	Hz
43	Maximum Current in Interval, Phase 1	A
44	Maximum Current in Interval, Phase 2	A
45	Maximum Current in Interval, Phase 3	A
46	Minimum Voltage in Interval, Phase 1	V
47	Minimum Voltage in Interval, Phase 2	V
48	Minimum Voltage in Interval, Phase 3	V
49	LEM Product ID (bits 7-10) Current calibre (bits 3-6) Connection schema (bits 0-2)	
50	Software Version (bits 8-15) Software Revision (bits 0-7)	
51	Status Word	
53	Recording Interval Time Setting	min

Register N°	Description	Unit
63	U rms phase A	V
64	Error status	
65	Serial error counter	
66	Meter error counter	
70	Nb of LSB for Zero Power Detection	LSB

4.1 Glossary and Symbols

- **RTC** Real Time Clock
- **UTC** Coordinated Universal Time. Number of seconds passed since 1.1.1970
- **SELV** Safety Extra Low Voltage
-  Equipment protected throughout by double isolation or reinforced isolation.
- **CAT III** Measurement category III is for measurements performed in the building installation.
-  «Caution, risk of danger» Documentation must be consulted in all cases where this symbol is marked
-  Caution, risk of electrical shock
-  Do not install or remove on conductors carrying hazardous 12 V
-  Protective conductor terminal
-  Direct current